

A PLANNED UNIT DEVELOPMENT

FLORIDA CLUB, P.U.D. PHASE III

A PARCEL OF LAND BEING A REPLAT OF PART OF LOTS 5, 6 AND 11 OF SECTION 8 TROPICAL FRUIT FARMS, RECORDED IN PLAT BOOK 3, PAGE 6, PALM BEACH COUNTY, (NOW MARTIN COUNTY) LYING IN SECTION 8, TOWNSHIP 39 SOUTH, RANGE 41 EAST

MARTIN COUNTY, FLORIDA
SHEET 4 OF 5 APRIL, 2002

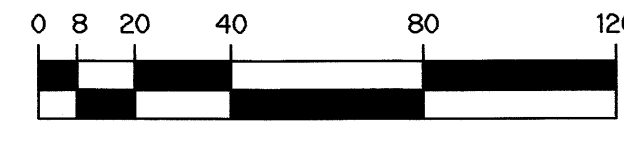

SCALE: 1" = 40'

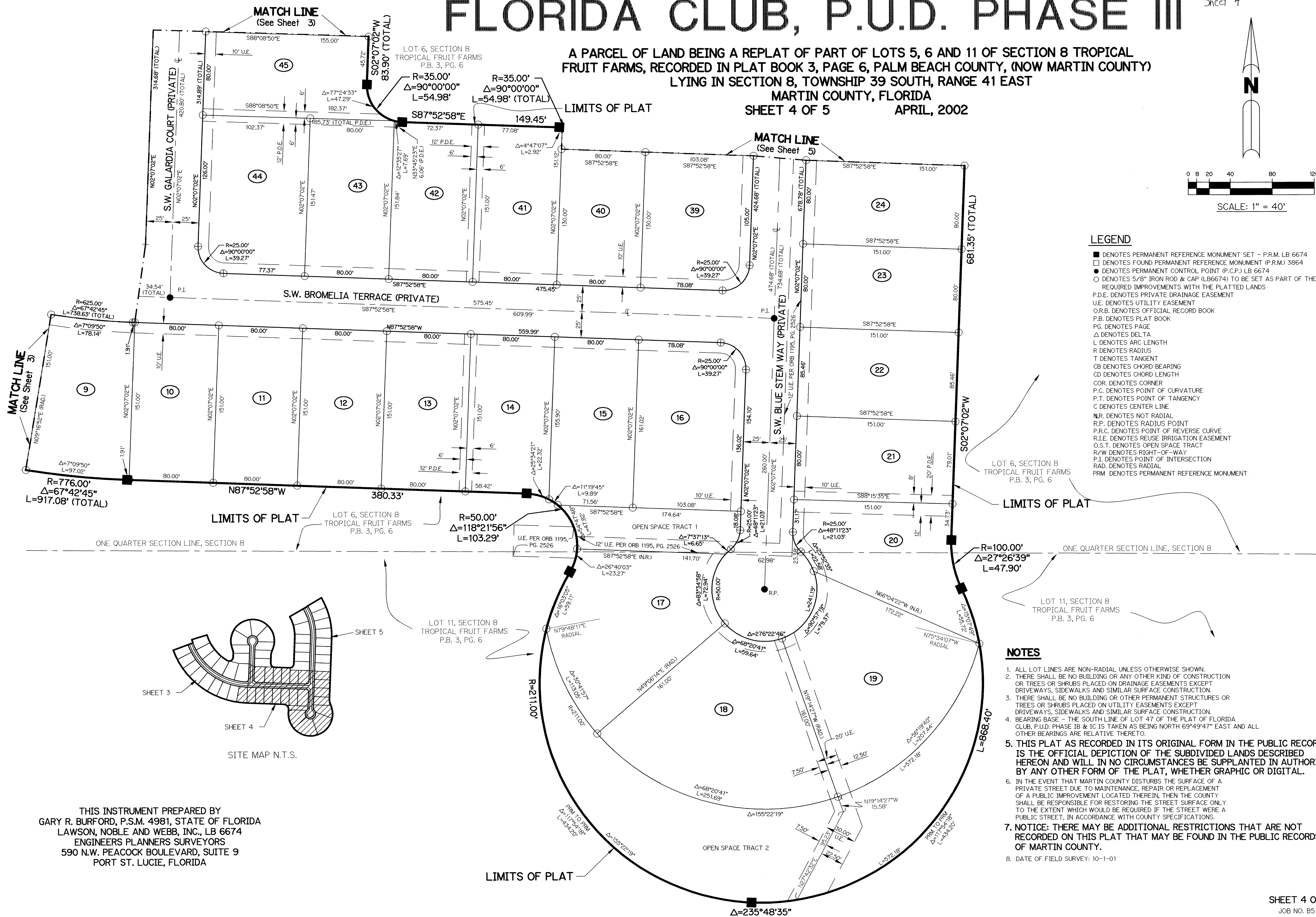

LEGEND

- DENOTES PERMANENT REFERENCE MONUMENT SET - P.R.M. LB 6674
- DENOTES FOUND PERMANENT REFERENCE MONUMENT (P.R.M.) 3864
- DENOTES PERMANENT CONTROL POINT (P.C.P.) LB 6674
- DENOTES 5/8" IRON ROD & CAP (LB6674) TO BE SET AS PART OF THE REQUIRED IMPROVEMENTS WITH THE PLATTED LANDS
- P.D.E. DENOTES PRIVATE DRAINAGE EASEMENT
- U.E. DENOTES UTILITY EASEMENT
- O.R.B. DENOTES OFFICIAL RECORD BOOK
- P.B. DENOTES PLAT BOOK
- P.G. DENOTES PAGE
- Δ DENOTES DELTA
- L DENOTES ARC LENGTH
- R DENOTES RADIUS
- T DENOTES TANGENT
- CB DENOTES CHORD BEARING
- CD DENOTES CHORD LENGTH
- COR. DENOTES CORNER
- P.C. DENOTES POINT OF CURVATURE
- P.T. DENOTES POINT OF TANGENCY
- C DENOTES CENTER LINE
- N.R. DENOTES NOT RADIAL
- R.P. DENOTES RADIUS POINT
- P.R.C. DENOTES POINT OF REVERSE CURVE
- R.I.E. DENOTES REUSE IRRIGATION EASEMENT
- O.S.T. DENOTES OPEN SPACE TRACT
- R/W DENOTES RIGHT-OF-WAY
- P.I. DENOTES POINT OF INTERSECTION
- RAD. DENOTES RADIAL
- PRM DENOTES PERMANENT REFERENCE MONUMENT

NOTES

1. ALL LOT LINES ARE NON-RADIAL UNLESS OTHERWISE SHOWN.
2. THERE SHALL BE NO BUILDING OR ANY OTHER KIND OF CONSTRUCTION OR TREES OR SHRUBS PLACED ON DRAINAGE EASEMENTS EXCEPT DRIVEWAYS, SIDEWALKS AND SIMILAR SURFACE CONSTRUCTION.
3. THERE SHALL BE NO BUILDING OR OTHER PERMANENT STRUCTURES OR TREES OR SHRUBS PLACED ON UTILITY EASEMENTS EXCEPT DRIVEWAYS, SIDEWALKS AND SIMILAR SURFACE CONSTRUCTION.
4. BEARING BASE - THE SOUTH LINE OF LOT 47 OF THE PLAT OF FLORIDA CLUB, P.U.D. PHASE IB & IC IS TAKEN AS BEING NORTH 69°49'47" EAST AND ALL OTHER BEARINGS ARE RELATIVE THERETO.
5. THIS PLAT AS RECORDED IN ITS ORIGINAL FORM IN THE PUBLIC RECORDS, IS THE OFFICIAL DEPICTION OF THE SUBDIVIDED LANDS DESCRIBED HEREON AND WILL IN NO CIRCUMSTANCES BE SUPPLANTED IN AUTHORITY BY ANY OTHER FORM OF THE PLAT, WHETHER GRAPHIC OR DIGITAL.
6. IN THE EVENT THAT MARTIN COUNTY DISTURBS THE SURFACE OF A PRIVATE STREET DUE TO MAINTENANCE, REPAIR OR REPLACEMENT OF A PUBLIC IMPROVEMENT LOCATED THEREIN, THEN THE COUNTY SHALL BE RESPONSIBLE FOR RESTORING THE STREET SURFACE ONLY TO THE EXTENT WHICH WOULD BE REQUIRED IF THE STREET WERE A PUBLIC STREET, IN ACCORDANCE WITH COUNTY SPECIFICATIONS.
7. NOTICE: THERE MAY BE ADDITIONAL RESTRICTIONS THAT ARE NOT RECORDED ON THIS PLAT THAT MAY BE FOUND IN THE PUBLIC RECORDS OF MARTIN COUNTY.
8. DATE OF FIELD SURVEY: 10-1-01

THIS INSTRUMENT PREPARED BY
GARY R. BURFORD, P.S.M. 4981, STATE OF FLORIDA
LAWSON, NOBLE AND WEBB, INC., LB 6674
ENGINEERS PLANNERS SURVEYORS
590 N.W. PEACOCK BOULEVARD, SUITE 9
PORT ST. LUCIE, FLORIDA

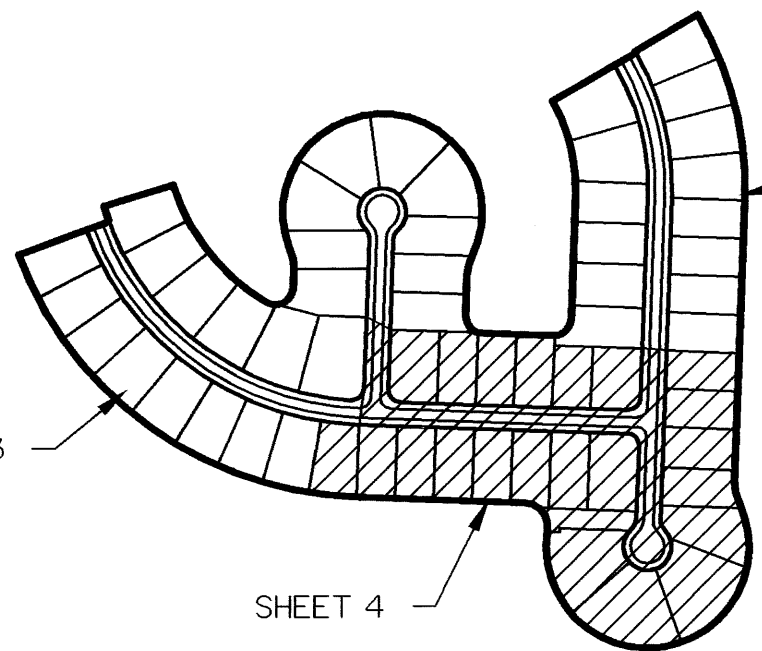

I:\Data\500-599\B519\CAD\B519PL04.dwg 04/09/2002 01:37:40 PM EDT